

Service Manual

**PowerBoss**<sup>®</sup>  
The Power of Clean

**For the ADMIRAL 26,  
ADMIRAL 2832 PLUS,  
& ADMIRAL 35 Automatic Scrubbers**



For:  
Training  
Troubleshooting  
Adjustments



Rev. OCT 2012

# Contents

**PowerBoss**<sup>®</sup>  
The Power of Clean

1	Cautions -----	Page 4
2	Maintenance Intervals -----	Page 5
	2.1 Customer Maintenance -----	Page 6
	2.2 Maintenance I after every 125 hours of operation-----	Page 7
	2.3 Maintenance II after every 250 hours of operation-----	Page 8
	2.4 Maintenance S after every 500 hours of operation, minimum once per year-----	Page 9
3	Service Mode -----	Page 10
	3.1 Service Mode -----	Page 11
	3.2 Service Mode Admiral 26 -----	Page 12
4	Brush Pressure Settings-----	Page 13
	4.1 ADMIRAL 2832 -----	Page 14
	4.2 ADMIRAL 26-----	Page 15
	4.3 Phoenix832XL, CP2832 and Phoenix 30 and 34-----	Page 16-17
5	Error Codes -----	Page 18
	5. Table of Error Codes (LCD)-----	Page 19-22

# Contents

**PowerBoss**<sup>®</sup>  
The Power of Clean

5.2 Error Codes (LED) -----	Page 21
6 Side Squeegee Adjustment (cylindrical) -----	Page 25
6.1 Side Squeegee Adjustment (disk)-----	Page 26
7 Rear Squeegee Adjustments -----	Page 27-29
8 Replacing the Brush Actuator On 2832 Models-----	Page 30
9 Trouble Shooting the Code 8 Error -----	Page 33
10 Testing the Throttle Potentiometer-----	Page 36
11 Identifying the Cause of Trio Controllers -----	Page 38
12 Notes-----	Page 39

# 1. Cautions

**PowerBoss**<sup>®</sup>  
The Power of Clean

- Always disconnect the A.C. Cord from the outlet and and D.C. Cord from the battery pack before servicing the machine. Except for making voltage and current measurements.
- Before replacing or disconnecting any electrical componets, disconnect the battery pack from the machine first. Failure to do so could cause a short circuit.
- After any repair work test the machine for proper operation.
- When servicing the machine always observe the general safety and accident prevention guidlines.
- Do not attempt to power up the controllers with battery chargers. Permanent damage will occur to the controller.  
36 volt chargers usually have an output in excess of 48 volts.
- Use only Minuteman approved battery chargers.
- Do not apply power directly to the motors without first disconnecting them from the controller circuit.

## 2. Maintenance Intervals

- Maintenance Intervals:**

In a modular structure, the Power Boss System Maintenance determines the specific technical procedures to be performed and sets the time interval between the two maintenance cycles.

For each of the maintenance cycle, the replaceable parts are determined as well. Further details described in the specific chapters.

- Power Boss System Maintenance K:**

To be performed by the customer (in daily or weekly intervals) according to the maintenance and care instructions as specified in the operating instructions.

The operator must be professionally instructed after delivery of the machine by selling dealer.

- Power Boss System Maintenance I:** (after every 125 hours of operation)

To be performed an authorized Power Boss Service Center in accordance with the machine-specific system maintenance.

- Power Boss System Maintenance II:** (after every 250 hours of operation)

To be performed an authorized Power Boss Service Center in accordance with the machine-specific system maintenance.

- Power Boss System Maintenance S:** (after every 500 hours of operation, safety check)

To be performed by an authorized Power Boss Service Center in accordance with the machine-specific system maintenance.

## 2.1 System Maintenance K

To Be Performed By Customer	Interval	
	Daily	Weekly
Perform the Minuteman System Maintenance K	o	
Fill the clean water tank and mix the proper amount and type of cleaning solution.	o	
Charge the batteries.	o	
Check the brush head. Clean, if needed with a damp cloth. Do not get water inside of the motors.	o	
Check the squeegee, clean if needed.	o	
Check the lid gasket on the recovery tank	o	
Empty and flush the recovery tank with clean water.	o	
Clean the filter inside of the recovery tank. If missing replace.	o	
Check the water levels all the batteries. Add distilled water, if needed. Do not over fill.	o	
Check the brushes and pads for wear. Replace if needed.		o
Check the squeegee hose for clogs, damage and wear. Replace if needed.		o
Check the squeegee rubbers for wear and cuts. Flip the rubber blades over or replace.		o
Check the solution filter. Clean if needed.		o
Flush the clean water tank and system with warm water.		o
Test all the functions of the machine.		o

## 2.2 System Maintenance I

To Be Performed By An Authorized Service Center	Interval
	Every 125 hours of operation
Perform the Minuteman System Maintenance I	0
Check the battery charger. Make sure it is functioning correctly.	0
Check the recovery lid gasket. Replace if needed.	0
Lubricate the brush lift linkages with grease. Use a small brush.	0
Check for loose hardware, tighten if needed.	0
Check the tire pressure on pneumatic wheels at 65 psi, if equipped.	0
Lubricate the squeegee linkages with grease. Use a small brush.	0
Inspect the entire machine for damage, wear and proper operation.	0



## 2.3 Minuteman System Maintenance II

To Be Performed By An Authorized Service Center	Interval
	Every 250 hours of operation
Perform the Minuteman System Maintenance II	0
Inspect the caster wheels for wear and damage. Repair, if needed.	0
Inspect the carbon brushes for wear in the transaxle. Replace, if needed.	0
Inspect the recovery drain hose for wear or damage. Replace, if needed.	0
Inspect the brush bumper rollers for wear or damage. Replace, if needed.	0
Inspect the carbon brushes in the brush motors for wear. Blow out with compressed air.	0
Inspect the recovery hose for damage or wear. Replace, if needed.	0
Inspect the squeegee assembly for proper adjustment. Repair, if needed.	0
Test the machine for proper operation.	0



## 2.4 System Maintenance S

To Be Performed By An Authorized Service Center	Interval
	Every 500 hours of operation
Perform the Minuteman System Maintenance check	0
Replace the carbon brushes in the transaxle.	0
Replace the carbon brushes in the brush motors.	0
Test the machine for proper operation.	0

# 3. Service Mode

The Service mode switch can be used to lower the brush deck. Press and hold the switch in the down position and the deck will lower. Once it is in service mode, the deck can be raised and lowered by pressing the top or lower part of the rocker switch. To return the machine back to normal operation: Turn the key switch off and back on. The machine will reset.

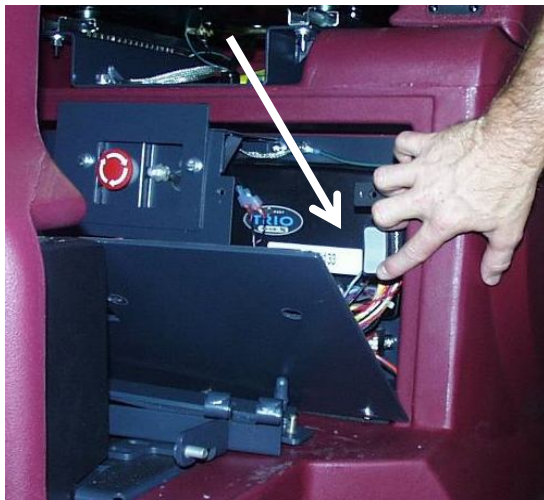

The switch located below the seat behind the panel on the right side on the Admiral 28 and 32 XL models.

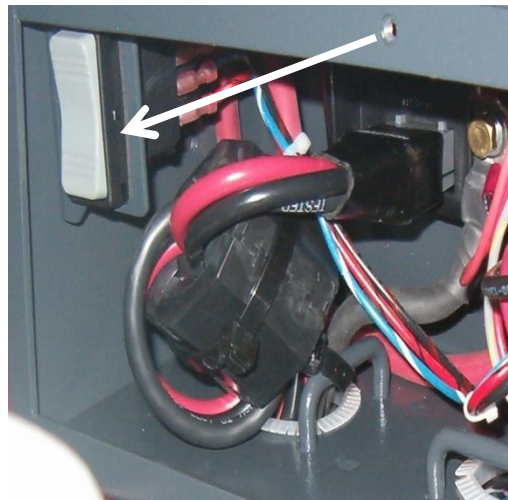

The switch is located behind the panel on the left side on the Admiral 26.

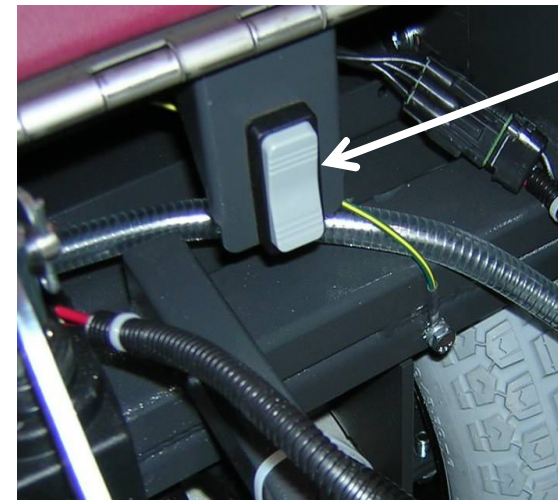

The switch is located below the recovery tank on the CP2832 and Phoenix 34 and Phoenix 28 and 32XL models.

# 3.1 Service Mode

## **SC280000 and SC3200000 Models Only (Old Style)**

Push and hold the brush pressure down button for 15-20 seconds.

Once it is in service mode, You can raise and lower the deck buy pressing the brush pressure up and down arrows.

To return the machine back to normal operation: Turn the key switch off and back on. The machine will reset.



## 3.2 Service Mode

**PowerBoss**<sup>®</sup>  
The Power of Clean

### Admiral 26 Only

The Service Mode Switch on the Admiral26 is located next to the step on the front of the machine on the operator's left side.

Once it is in service mode, the deck can be raised and lowered by pressing the upper or lower part of the rocker switch.

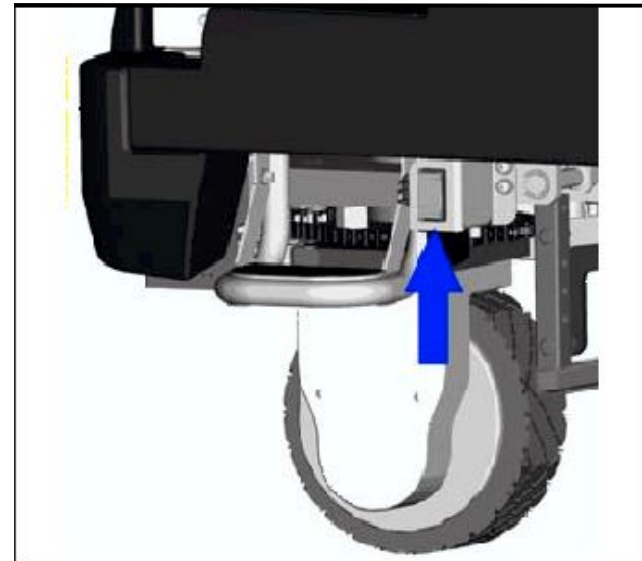

To return the machine back to normal operation: Turn the key switch off and back on. The machine will reset.



# 4. Brush Pressure Settings

The brush pressure range can be changed when changing the type of deck on the Admiral 2832 PLUS, Admiral 26, Phoenix 2832 XL models.

Connect the orange/violet wire into the terminal block with red/black wire group for cylindrical decks and unplug it for the disk decks.

The terminal block is located below the Trio controller on the Admirals and below the control panel on the Phoenix 2832XL.

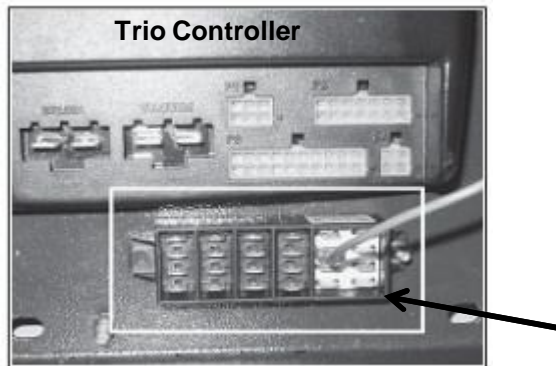

SCV 2832E Shown

## Trio Pressure Settings

748400 Admiral 28 and 32XLs			
Setting	Disk Pressure	Amps	Orange/violet Wire
1	Light Disk	28	Not connected
2	Double Both	33	Not connected
3	Heavy Disk	33	Not connected
4	Light Cylindrical	23	Connected
5	Heavy Cylindrical	30	Connected

748270 & 748271 Admiral 26			
Setting	Disk Light Pressure	Amps	Orange/violet Wire
1	Light Disk	23	Not connected
2	Double Both	28	Not connected
3	Heavy Disk	28	Not connected
4	Light Cylindrical	23	Connected
5	Heavy Cylindrical	26	Connected

747010 Phoenix 2832 XL			
Setting	Disk Light Pressure	Amps	Orange/violet Wire
1	Light Disk	30	Not connected
2	Double Both	40	Not connected
3	Heavy Disk	40	Not connected
4	Light Cylindrical	17	Connected
5	Heavy Cylindrical	25	Connected

## 4.2 Brush Pressure Settings

**PowerBoss**<sup>®</sup>  
The Power of Clean

The brush pressure range can be changed when changing the type of deck on the ER26 and SC2426 models.

Connect the orange/violet wire into the terminal block with red/black wire group for cylindrical decks and unplug it for the disk decks.

The terminal block is located below the Trio controller on the ER26 and SC2426 models.

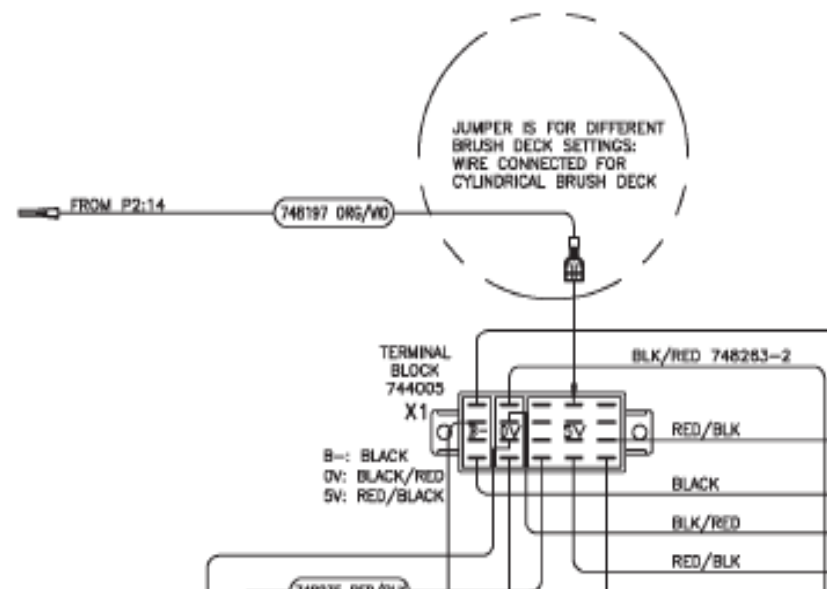

ER26 and SC26P Shown

## 4.3 Phoenix 28/32 XL

**PowerBoss**<sup>®</sup>  
The Power of Clean

It is now available to change the brush pressure settings in the field, when changing brush decks on current production models of the Phoenix 28/32 XL. No other modifications will be required.

Changing the brush pressure settings will only be required, when changing the cylindrical over to the disk deck or disk over to the cylindrical decks. Changing the size only (Example: Changing the 28 disk to 32 disk) will not require changing the settings.

The orange/violet wire from the controller has been added to change settings.

Connecting the orange/violet wire to the terminal block puts it in the low-pressure mode for cylindrical decks.

Disconnecting the orange/violet from the terminal block puts the brush pressure in the high-pressure mode for disk decks.

### Instructions:

1. Remove the switch panel, by removing the four screws.
2. Locate the terminal block. See Photograph.

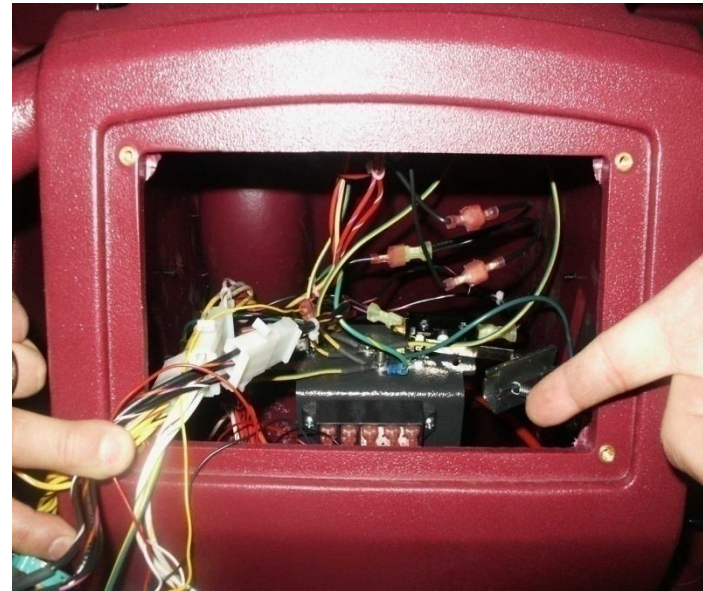



## 4.2 Phoenix 28/32 XL



Locate the Red/Black wire group

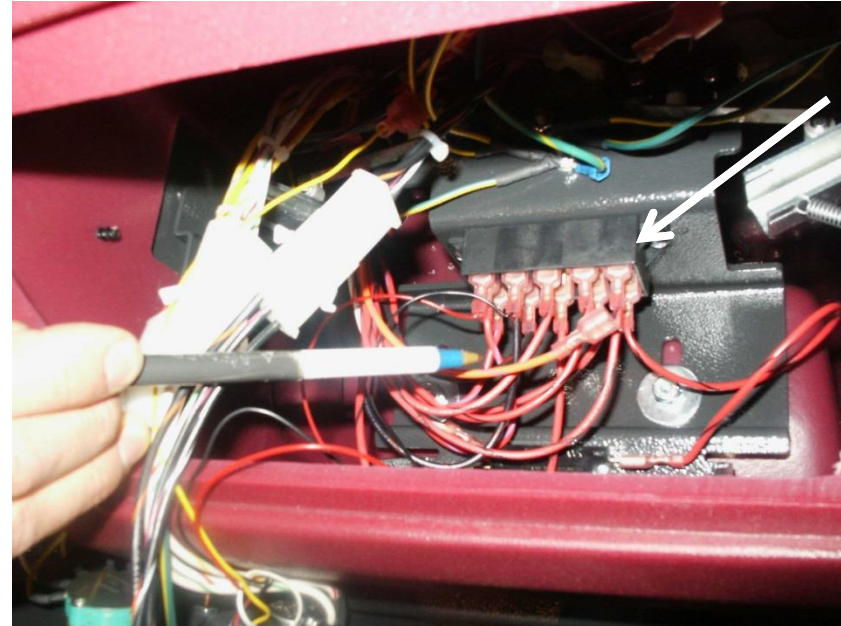

Locate the Orange/Violet wire

## 5. Error Codes

The Phoenix 28/32 XL model uses a 10 light LED display to indicate the battery condition and error codes. The battery condition will be displayed with 1 to 10 LEDs. 10 LEDs would be a fully charged battery one LED batteries are discharged.

When a error occurs 1 to 10 LEDs will flash indicating a specific error has occurred. There are two aspects of the error codes.

- A. How many LEDs are flashing
- B. How many times it is flashing ( referred to as sequence)

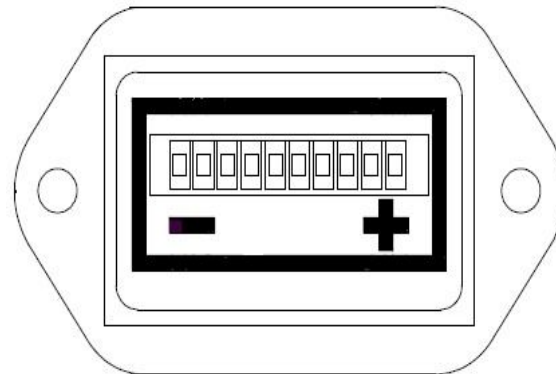

## 5.1 Table Error Codes (LED)



Single flash Low Batteries- Charge the batteries



Single flash Traction drive motor overload, Has two levels soft (warning) and critical (shut down)



Single flash - Brush motor fault (disconnected or over load)



Single flash - Brush actuator overload



Two flash – Squeegee actuator overload

## 5.1 Table Error Codes (LED)



Single flash – Vacuum motor fault (disconnected or overload)



Single flash- Off Isle Wand Activated



Single flash- Throttle (potentiometer) fault



Single flash- Control fault, check all connections to controller- see "Trouble Shooting the Code 8 Error"

## 5.1 Table Error Codes (LED)

**PowerBoss**<sup>®</sup>  
The Power of Clean



Single Flash- Solution tank empty- Riders only



Two flash-Not used



Three flash-Water solenoid fault



Four flash-Water pump fault



Five flash-Electric brake circuit fault- Check all connections to the electric brake (e-mag).

## 5.1 Table Error Codes (LED)

**PowerBoss**<sup>®</sup>  
The Power of Clean



Single flash- High battery voltage- Check all connections

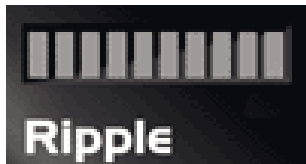

Ripple-Throttle activated during start up.



## 6. Side Squeegee Adjustment

**PowerBoss®**  
The Power of Clean

ER26, ER2832, SCV2426 & SCV2832E Only

The side squeegees on the cylindrical decks can be adjusted by loosening the two black knobs and moving the squeegee assembly up or down.

The brush assembly may be accessed by removing the yellow knob C. The squeegee assembly is hinged at D.

Remove the three wing nuts that mount the brush idler bearing assembly E and remove the brush roll.

Repeat the process on both sides of the machines

### Cylindrical Decks

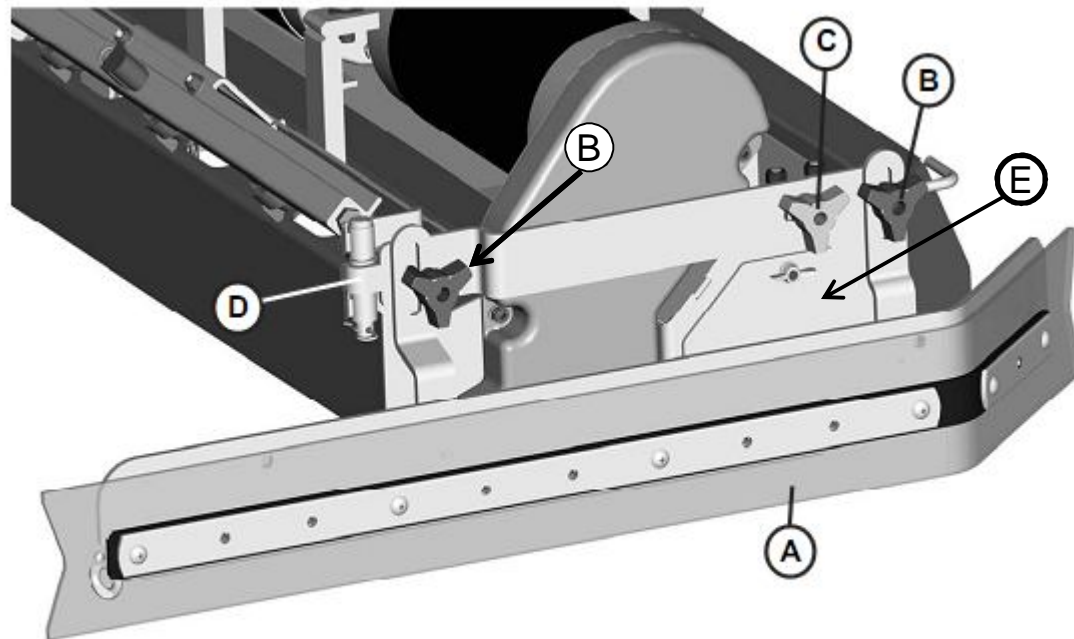

- A-Side Squeegee
- B-Black Adjustment Knob
- C-Yellow Brush Access Knob
- D-Side Squeegee Hinge
- E-Bush Access Plate



## 6.1 Side Squeegee Adjustment

ER26, ER2832, SCV2426 & SCV2832E Only

**PowerBoss**<sup>®</sup>  
The Power of Clean

The side squeegee assemblies can be adjusted by loosening the two wing nuts and moving the assembly up or down.

Repeat the process on both sides, if needed.

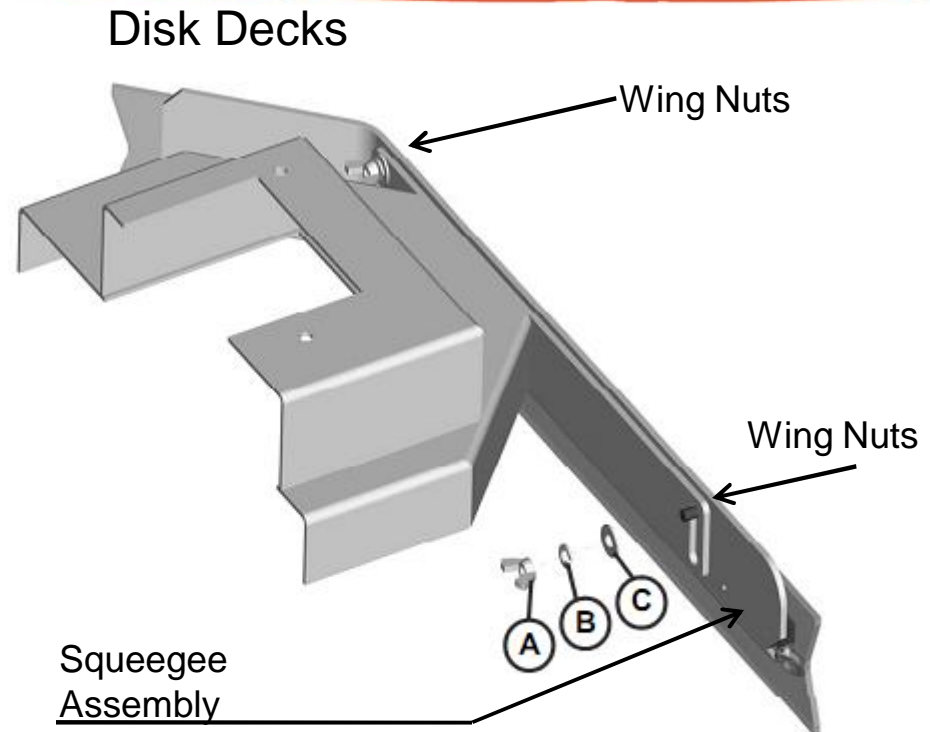

A	Wing Nut for Squeegee Adjustment (2)
B	Helical Lock Washer for Squeegee Adjustment (2)
C	Flat Washer for Squeegee Adjustment (2)

## 7. Squeegee Adjustment

**PowerBoss**<sup>®</sup>  
The Power of Clean

### For ER26 and ER2832

The pitch of the squeegee can be adjusted by loosening the jam nuts.

Adjust the position of the nuts until squeegee sets level to the floor.

Tighten the jam nuts to lock into position

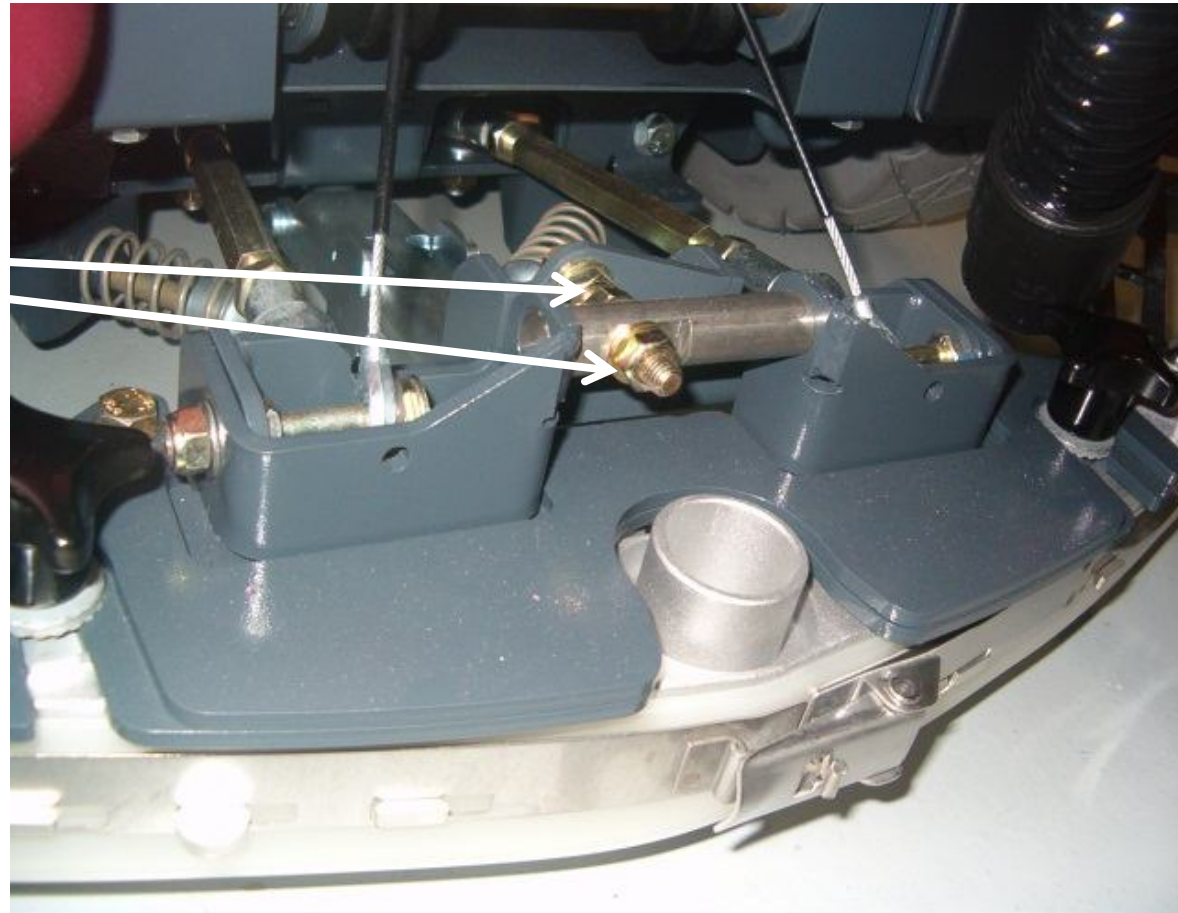

# 7.1 Rear Squeegee Adjustment

ER26 and ER2832 Only

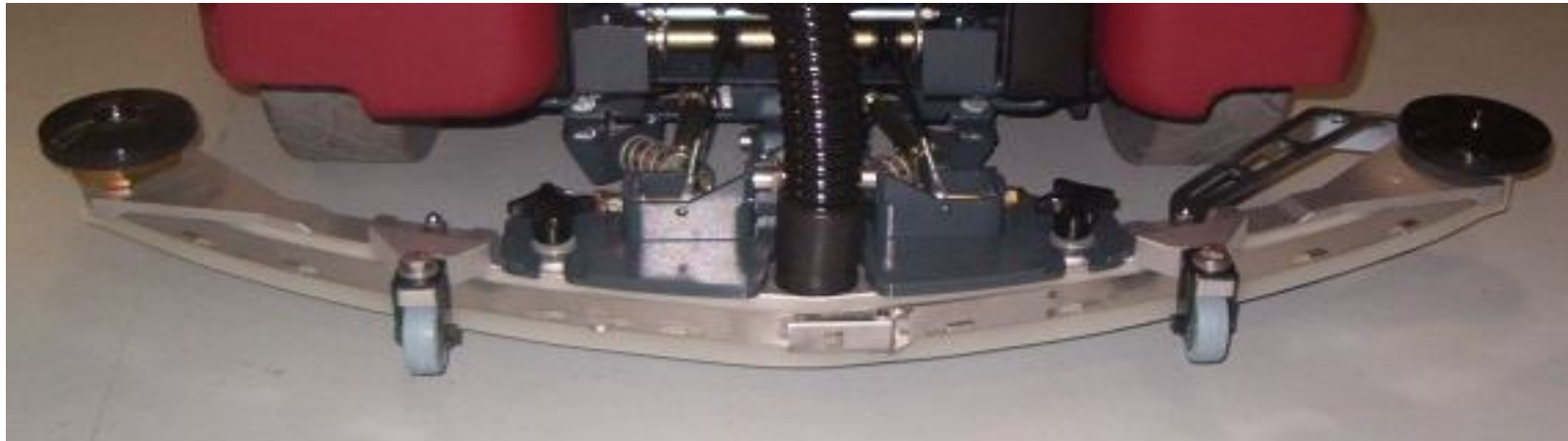

The rear squeegee assembly must be adjusted so the bottom of the rear squeegee blade sets level to the floor. The dotted line on right represents the floor.



Incorrect setting above



Incorrect setting above

## 7.2 Squeegee Caster Adjustment

**PowerBoss**<sup>®</sup>  
The Power of Clean

Clearance between support roller and floor with unfolded sealing strip (Factory presetting): 3 mm  $\pm$ 0.5 (Fig. 5/2). Place additional 1mm spacers between the angle and the fixed roller housing to increase clearance or remove existing 1mm spacer from between the angle and the fixed roller housing in order to reduce the clearance. Re-insert the spacers removed from between the angle and the fixed roller housing again above the fixed roller housing to allow complete tightening of the screws.

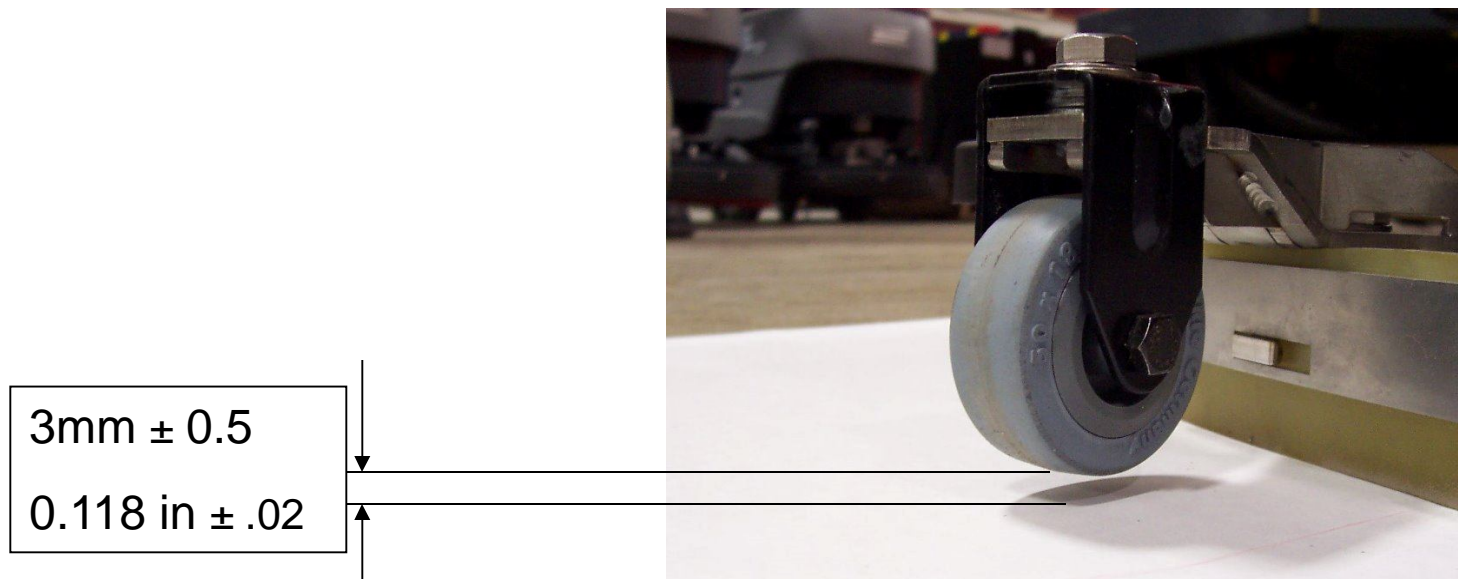

## 7.3 Squeegee Caster Adjustment

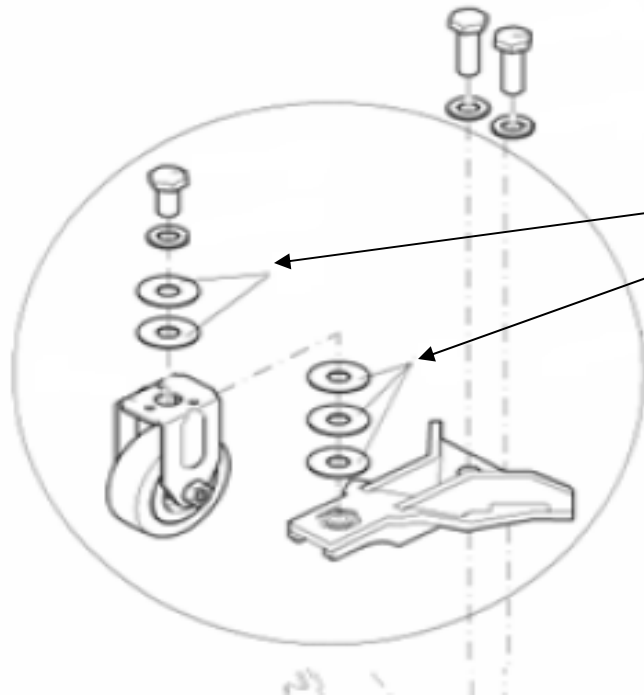

**Washers may be rearranged to change the height of the squeegee caster.**

**Note: When adjusting the wheel height, there should always be 5 washers on each wheel assembly in order fully tighten bolts. Move washers from the top to the bottom of the bracket or visa versa when making adjustments. See following page.**



## 9. Trouble Shooting the Code 8 Error

### Phoenix 28/32 XL Model

1. Disconnect one motor connector from the Trio controller at a time and disconnect the batteries for two minutes.
2. Reconnect the battery pack and turn the machine with one motor disconnected.
3. Repeat this process with each motor.
4. If the code 8 disappears and is replaced by a different code, the circuit disconnected should be considered suspect. For example, if the brush was disconnected and the code 8 is replaced by code 3, the code 3 indicates the brush motor is disconnected. Check for a shorted motor, broken harness or broken connection at the brush deck.
5. Check to see if water has gotten inside the brush motor, if it is suspected as the failure.
6. Check for a shorted motor.
7. On the Phoenix 28/32 XL model only, disconnect the plug on the Service Mode Switch. This is accessible by tilting the solution tank forward. Power the machine up with it disconnected. If error code is cleared replace the switch.
8. Static electricity. Check both the ground chains; there is one on the brush deck and one on the rear of the machine. The one in the rear should be contacting the floor. The one on the deck should touch the floor when the deck is down. They also should have continuity between the end of the chain and the frame of the machine. Repair or clean if needed if needed.

## 9. Trouble Shooting the Code 8 Error

9. Check for a disconnected or an open circuit or faulty potentiometer on the throttle or speed circuit. The controller may not be detecting it in the circuit. Do a continuity test. See “**Testing the Throttle Control Potentiometer**” see section 10.
10. If the code 8 always shows after completing all the above tests, the controller will need to be replaced. Complete the following tests before changing the controller.  
**Note: Controllers can be damaged by loose connections, static electricity and water on electrical components such as on or in the controller and motors.**
11. Check for loose or burnt connections on the controller, batteries, cables and the circuit breaker. Make the sure the circuit breaker is not damaged (burnt or cracked).
12. Test the chassis drive motor harness for broken wires. Disconnect the plug labeled “Traction” on the Trio controller. Connect a digital multi-meter into the pins of the plug on the two large wires. Set the meter for Ohms (resistance). The 281400 and 241400 chassis drive motors on the Admiral 26 and Admiral 28/32 Plus models (this has red or dark blue wheel) they should have resistance of 3.9 to 5.7 ohms. Turn the steering wheel slowly in both directions until it stops several times. Monitor the meter while turning. The resistance should not change or vary while turning. Any variation even .1 ohm would be indicate a broken wire, which could cause spikes and surges, that could damage the Trio controller permanently.



## 9. Trouble Shooting the Code 8 Error



13. Test the two small wires on the “Traction” harness for resistance that go the electric brake (E-Mag). The resistance should be 60 to 80 ohms. Turn the steering wheel slowly in both directions until it stops several times. Monitor the meter while turning. The resistance should not change or vary while turning. Any variation even .1 ohm would be indicate a broken wire or poor connection.
14. Measure the total battery voltage at the batteries and at the battery connections on the controller. They should be exactly the same. A 1/10 of a volt or more difference would indicate a problem in the connections.
15. Repair or replace any parts needed before replacing controller.

## 10. Testing the Throttle Potentiometer

1. Check for a open or faulty potentiometer circuit
2. The throttle potentiometer resistance can be measured with an ohmmeter.
3. *Analog type meters are recommended for this test, not digital.*
4. Locate the Trio controller. Unplug the P3 connector (the large white connector with 14 pins) on the controller under the seat on the riders in the metal compartment.
5. Locate black/white and the black/orange wires. The resistance measured across them should be 5K. If not, check the connection near the throttle control potentiometer.
6. If step 5 checks OK, locate the black/orange and the black/pink wire on the P3 connector. On the Phoenix 28/32 XL walk behind scrubbers, the potentiometer must be in the full counter clock wise position and the drive switch activated. The seat switch will need to be activated during this test on riders. Measure the resistance across the two. It should be zero ohms in the neutral position. It should be about 5k in the full throttle position. The potentiometer will need to be adjusted slowly while making the test. **Note: when moving the throttle to the full position, the resistance should be smooth, without dropping out for both tests. If the resistance does not go to 5K (± 20%) during the test, the arm and the potentiometer may need to be adjusted to achieve it on the riders.**
8. If your reading is different with this test, check all the connections between the controller and the throttle control potentiometer, including the seat switch (Riders only). Retest at the connector near the throttle control potentiometer.
9. Unplug the throttle control potentiometer at the connector next to it.
10. Measure the resistance across the red and white wire on the potentiometer assembly. It should measure approximately 5K (5 thousand ohms ± 20%).

## 10. Testing the Throttle Potentiometer

**PowerBoss**<sup>®</sup>  
The Power of Clean

9. **Admiral 28/31 Plus Riders Only:** Measure resistance across the black and white wires on the potentiometer, the resistance should be zero ohms with pedal on the riders in the neutral position. When the pedal or knob is moved to the full throttle position, in should be a smooth resistance change without dropping out. It should measure approximately 5K (5 thousand ohms) in the full position.

**Phoenix 28/32 XL Only:** Disconnect the potentiometer at the connector next to it. Measure resistance across the black/orange and black/white wires should be 5 K ohms.

12. **Admiral 28/31 Plus Riders Only :** Measuring across the black and the red wire the resistance should be approximately 5K (5 thousand), when in the neutral position. When the pedal is at full throttle or the knob is full speed position, the resistance should drop to zero without being intermittent.

**Phoenix 28/32 XL Only :** Disconnect the potentiometer at the connector next to it. Measure the resistance across the black/orange and black/pink wires. The resistance should drop to zero without being intermittent when turning the knob of the potentiometer. Note: The drive switch will need to be activated when doing this test.

13. If adjustment is needed, loosen the nut and screw on the throttle arm. Adjust the potentiometer shaft with a flat tip screw driver, until it is set according to the information above (on the riders only).

14. Reconnect the plug at the throttle potentiometer.

**Note: when moving the throttle to the full position, the resistance should be smooth, without dropping out for both tests. If the resistance does not go to 5K during the test, the arm and the potentiometer may need to be adjusted to achieve it.**

Potentiometer Assembly – Riders only

Adjust Here

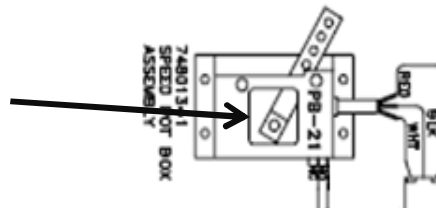

# 11. Identifying the Cause of Trio Failures **PowerBoss**<sup>®</sup> The Power of Clean

1. Check for loose or burnt connections on the controller, batteries, cables and the circuit breaker. Make the sure the circuit breaker is not damaged (burnt or cracked).
2. Test the chassis drive motor harness for broken wires. Disconnect the plug, labeled 'Traction' on the Trio controller. Connect a digital multi-meter to the plug on the two large wires. Set the meter for Ohms (resistance). The Admiral 28/32 Plus chassis drive motor #281400 (has red or dark blue wheel) should have resistance of 3.9 to 5.7 ohms. The Turn the steering wheel slowly in both directions until it stops several times. Monitor the meter while turning. The resistance should not change or vary while turning. Any variation even .1 ohm could be indicating a partially broken or broken wire, which could cause spikes and surges. This could possibly damage the Trio controller.
3. Test the two small wires on the "Traction" harness that go the electric brake (E-Mag). The resistance should be 60 to 80 ohms. Turn the steering wheel in both directions until it stops several times. Monitor the meter while turning. The resistance should not change or vary while turning. Any variation even .1 ohm would be indicate a broken wire or poor connection.
4. Measure the total battery voltage at the batteries and at the battery connections on the controller. They should be exactly the same. A 1/10 of a volt or more difference would indicate a problem in the connections.

## 12. Notes

**PowerBoss**<sup>®</sup>  
The Power of Clean